

**PACKAGE OUTLINE DRAWING FOR 3L TO220**  
**MF-PO-D-0077 revision 0.0**

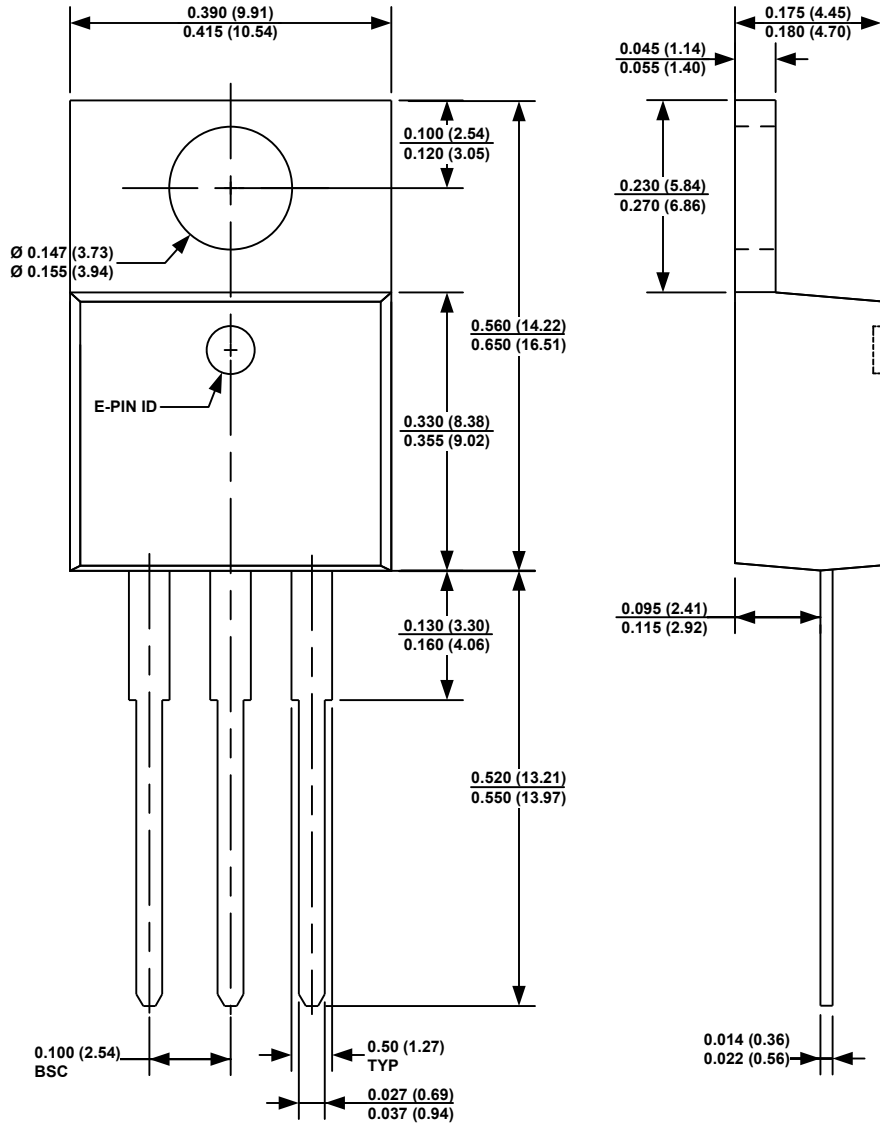

**TOP VIEW**

**SIDE VIEW**

**NOTE:**

- 1) CONTROL DIMENSION IS IN INCHES. DIMENSION IN BRACKET IS IN MILLIMETERS.
- 2) PACKAGE LENGTH DOES NOT INCLUDE MOLD FLASH, PROTRUSIONS OR GATE BURRS.
- 3) PACKAGE WIDTH DOES NOT INCLUDE INTERLEAD FLASH OR PROTRUSIONS.
- 4) DRAWING CONFORMS TO JEDEC TO-220
- 6) DRAWING IS NOT TO SCALE.